

GCS-2 Operation and Service Manual

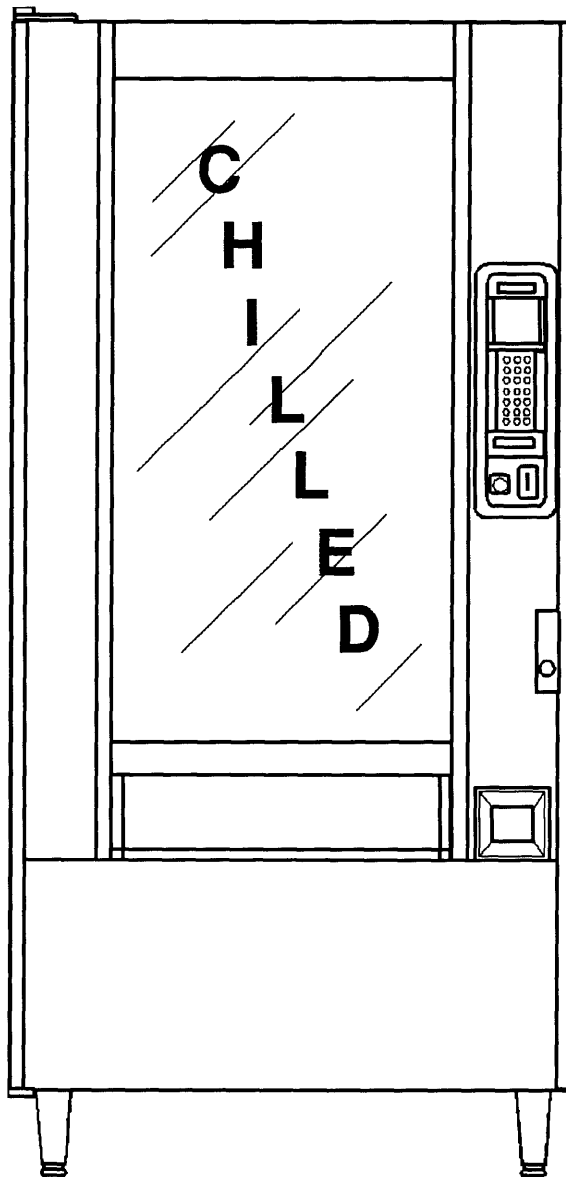

Glasco TM

12271 Natural Bridge
Suite 798
Bridgeton, MO 63044-9898
(314) 298-3510

GCS-2 Operation and Service Manual

This machine has been engineered to our own rigid safety and performance standards. It has earned a "Letter of Compliance" from NAMA indicating that it complies with sanitation and health guidelines recommended by the Automatic Merchandising Health-Industry Council (AMHIC) and it conforms with all other NAMA safety recommendations. This machine has been FCC verified.

This machine has been manufactured in accordance with the safety standards of both Underwriter's Laboratories and the Canadian Standards Association. To maintain this degree of safety and to continue to achieve the level of performance built into this machine, it is important that installation and maintenance be performed so as to not alter the original construction or wiring and that replacement parts are as specified in the parts section of your *Operation and Service Manual*. Your investment in this equipment will be protected by using this *Operation and Service Manual* in your operation, service, and maintenance work. By following prescribed procedures, machine performance and safety will be preserved.

This merchandiser is warranted for one (1) year against defective parts and workmanship. Any part or parts which are proven to be defective within one (1) year of the date of shipment will be repaired or replaced free of charge when the defective part is returned, with transportation charges prepaid, to the destination designated by the Glasco Warranty Department.

This warranty applies only to the original purchaser of the merchandiser and is null and void if the merchandiser is sold during the period of warranty.

This warranty is also null and void for all electrical components, wiring, or circuits and/or for all mechanical parts or assemblies damaged as a result of operating the merchandiser at other than 110-120 volts, 60 Hertz current. This warranty is null and void in the event of vandalism, fire, or negligence on the part of the operator.

No warranty is given or implied on incandescent lamps, neon lamps, fluorescent lamps, ballasts, starters, or other expendable items. No warranty will be given when other manufactured components are installed in Glasco merchandisers.

Further, Glasco is not responsible for any cost of service rendered or repairs made on merchandisers or parts by anyone other than an authorized Glasco distributor, unless authorization to incur such expense has been given in writing by Glasco prior to incurring such expense.

This warranty is in lieu of all warranties expressed or implied, including, without limitation, warranties of merchantability and all other obligations or liabilities on the part of Glasco. Furthermore, Glasco neither assumes nor authorizes any person to assume for it any other obligation or liability in connection with the sale of said equipment or any part thereof.

Glasco[™]
12271 Natural Bridge
Suite 798
Bridgeton, MO 63044-2063

GCS-2 Operation and Service Manual

PRELIMINARIES

POWER REQUIREMENTS Volts AC

115	
Amps	15
Hz	60
Phase	Single
Outlet	3-pin
Type	Grounded

CHECKING THE POWER OUTLET

Voltage Check

When placed across the HOT and NEUTRAL terminals, a volt-ohmmeter should indicate 110 - 130 volts AC.

Polarity Check

When placed across the HOT and GROUND terminals, a volt-ohmmeter should indicate 110 - 130 volts AC.

Noise Potential Check

When placed across the NEUTRAL and GROUND terminals, a volt-ohmmeter should indicate 0 volts AC. A reading of greater than 1.5 to 2.0 volts AC could result in noise problems for the electronic circuitry.

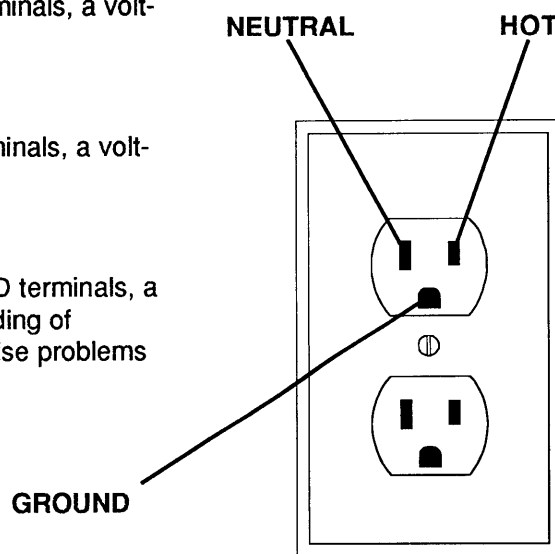

GCS-2 Operation and Service Manual

MACHINE SET-UP

1. Power to the merchandiser is controlled by the main power switch located on the power panel. The power panel is on the right side of the merchandiser, behind the monetary door. Make sure the power is turned off before proceeding with set-up.

Warning

You should unplug the merchandiser whenever you do one of the following:

- Change a fuse
- Change the fluorescent lamp
- Change the lamp starter
- Connect or disconnect a harness
(Except a motor harness when the tray has been removed)

2. *Read the following if you need to move the merchandiser through a narrow doorway.*

This merchandiser has the capability of passing through an opening as narrow as 30 inches by removing the cabinet extensions.

REMOVING THE TOP EXTENSION

Remove the two screws that secure each end of the extension to the sides of the cabinet. Remove the other four screws that secure the extension to the cabinet. Pull the extension forward to remove it from the merchandiser.

REMOVING THE DOOR CHECK

Remove the nut and bolt that secure the door check to the door check plate. Pull the door check fully forward, lift upward, and pull the short end of the check from the door check plate and spring assembly.

REMOVING THE BOTTOM EXTENSION

Remove the two screws that secure each end of the extension to the sides of the cabinet. Remove the other four screws that secure the extension to the bottom of the cabinet. Pull the extension forward and remove it from the cabinet.

TAKING THE MERCHANDISER THROUGH THE OPENING

- Open the cabinet door and place it square with the left side of the cabinet
- Carefully walk the merchandiser through the opening
(Please refer to the figure on the opposite page.)

GCS-2 Operation and Service Manual

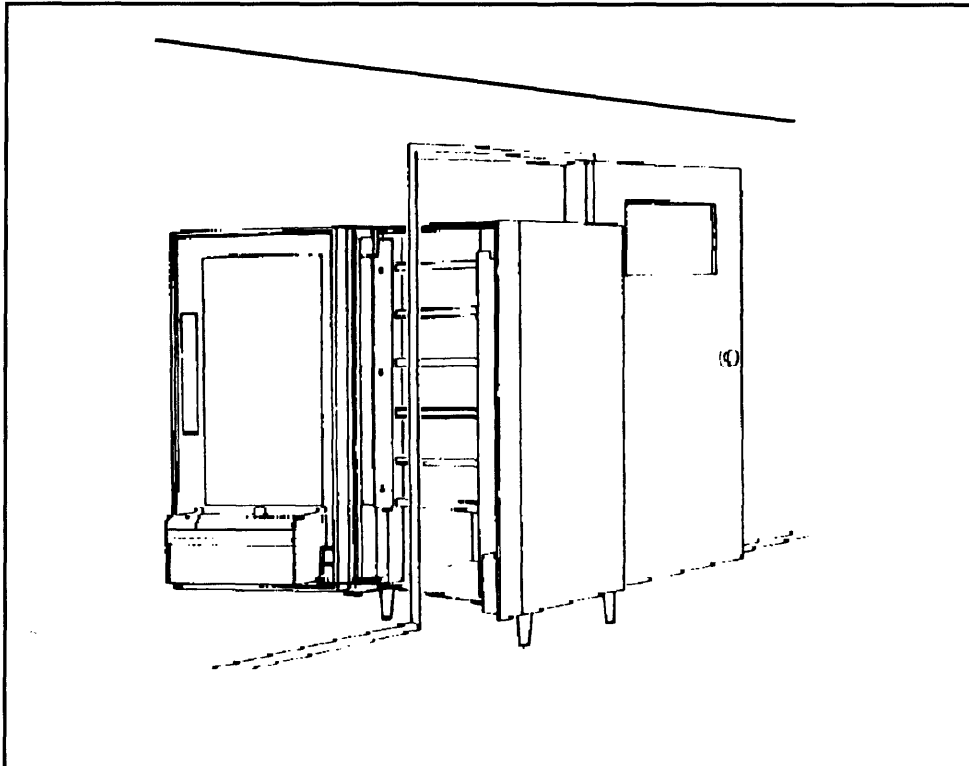

3.

POSITIONING THE MERCHANDISER

The GCS-2 can be positioned anywhere in a bank of machines. It can even be placed on an end flush against a side wall. However, it should have at least one inch of clearance between it and the back wall. Finally, there should be enough room in front of the merchandiser for the door to open freely.

Warning

This machine is only rated for installation in an indoor location.

4.

LEVELING THE MERCHANDISER

From a safety standpoint it is very important that the merchandiser be level. A level merchandiser is less likely to tip over and cause personal injury. Level the merchandiser by moving the leg levelers in or out for proper adjustment. Pliers or channel locks may be required to loosen the leg levelers. Level the merchandiser from the right to left and from front to back using a spirit level. When the merchandiser is part of a bank of machines, it should be leveled in reference to the other machines.

Caution

Have an assistant hold the merchandiser while you adjust the leg levelers.

Warning

Ensure that machine standoffs (P/N 4741065, in plastic bag) are installed. Failure to do this may decrease the life of the refrigeration unit compressor.

GCS-2 Operation and Service Manual

5.

COIN MECHANISM

Setting the Quarter Switch

If your coin mechanism is not a MARS TRC 6000, skip this procedure and begin loading the coin mechanism. If your coin mechanism is a MARS TRC 6000, flip down the top front of the mechanism and set the quarter switch as shown on the drawing to the right. Make sure switch #2 is in the down or "off" position.

Loading the Coin Mechanism

1. Open the cabinet door and the monetary cabinet
2. Insert coins into their respective tubes. Make sure each tube is full.
3. Inspect the tubes for shingled coins and correct if necessary.

6.

BILL VALIDATOR

Emptying the Stacker

1. Push up on the magazine latch to release the housing
2. Open the magazine by pulling it down.
3. Remove the bills and close the magazine. Make sure it is secure.

SETTING THE QUARTER SWITCH

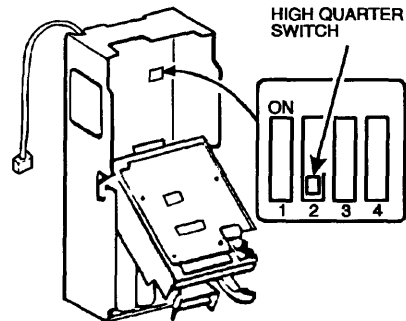

EMPTYING THE BILL STACKER

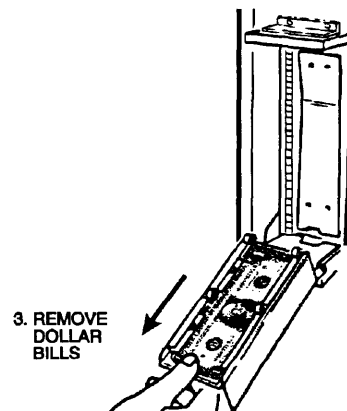
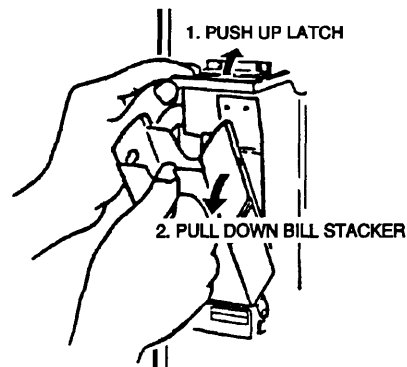

GCS-2 Operation and Service Manual

TRAY SET-UP

Putting The Tray In A Loading Position

Place both hands on the tray as shown in the figure below. Lightly push back on the tray with

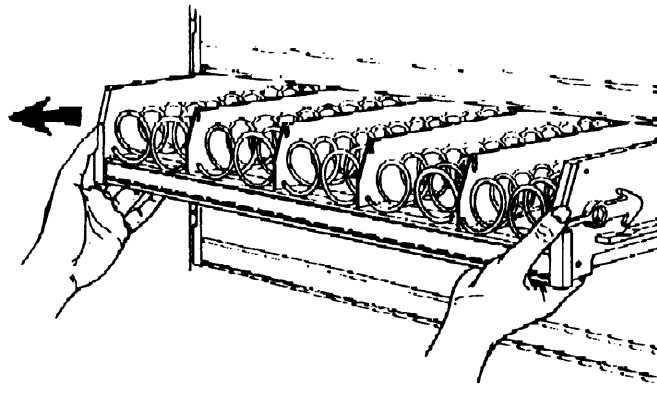

your palms. This will release the tray catches on the sides of the tray. Push down on the tray catches with your thumbs. Pull the tray forward until you hear and feel the rear rollers of the tray drop into a cut-out in the top of the guide rail. Continue pulling the tray forward into the loading position as shown in the figure below.

Removing A Tray

Push back on the tray slightly with your palms. This releases the tray catches. Push down on the tray catches with your thumbs. Pull the tray forward until you hear and feel the back rollers of the tray drop into the cut-out in the top of the guide rail.

Lift up on the tray and slide it towards the back. No more than one inch should be required. The tab near the back of the tray should align with the cut-out in the top of the guide rail. Lift the tray clear of the guide rail and out of the merchandiser.

GCS-2 Operation and Service Manual

Removing Column Dividers

Push the column divider toward the back of the tray. Lift the column divider clear of the tray. Please refer to the figure below.

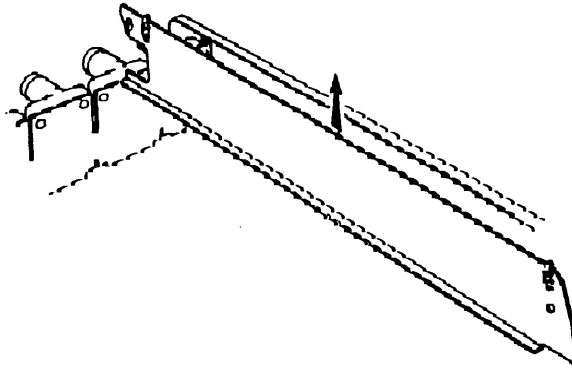

Removing And Installing Spirals

There are two important things you should remember about spirals:

- All spirals have the same diameter.
- There is a clockwise and a counter-clockwise spiral.

Spirals are available in six different capacities: 9, 11, 13, 15, 17, and 20. To remove a spiral, pull forward on the retaining clip and remove the end of the spiral from the spiral coupler. Remove the spiral from the tray.

To install a spiral, pull the bottom of the retaining clip towards the spiral. Lower the spiral into the tray column and insert the end of the spiral into the spiral coupler. Release the retaining clip.

GCS-2 Operation and Service Manual

Removing A Spiral Coupler

Pinch together the prongs on the end of the spiral coupler. Pull the coupler forward to remove.

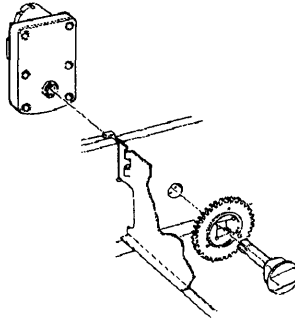

Installing A Spiral Coupler

Place gear in position if one is required for this set-up. Hold motor in place and push spiral coupler through the motor gear box until it clicks into place. When using a coupler bearing, hold the bearing in place and push the spiral coupler through the bearing until the coupler locks into position.

Installing A Gear

Gears are used to mechanically couple spirals together. This is required when you have two spirals and only one motor for vending a selection. The gear is placed between the back of the tray and the spiral coupler. There are two possible orientations for a gear.

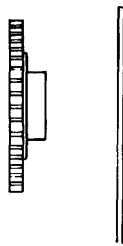

ORIENTATION 1

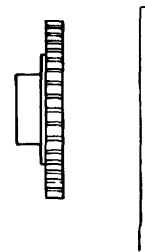

ORIENTATION 2

There are two rules to follow when orienting gears:

- RULE #1 The gears for selections next to each other cannot use the same orientation.

- RULE #2 All gears for a single selection must use the same orientation.

GCS-2 Operation and Service Manual

Disconnecting A Motor Harness

First, grasp the header on the motor circuit board. This will help prevent breakage of the circuit board. Next, Pull the harness connector away from the circuit board. Finally, tuck the unused part of the harness out of the way in the trough at the back of the tray.

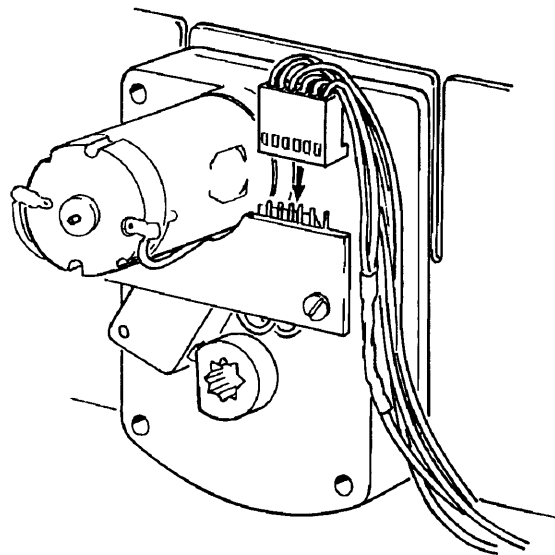

Connecting A Motor Harness

First, grasp the header on the motor circuit board. This will help prevent breakage of the circuit board. Next, locate the harness connector for the tray position of interest. Finally, push the harness connector over the header pins on the motor circuit board.

Removing A Spiral Motor (* = This procedure has been previously discussed)

First, place the tray in the loading position*. Then, disconnect the motor harness*. Next, Remove the spiral and the spiral coupler*. Finally, lift the motor clear of the tray.

Installing A Spiral Motor (* = This procedure has been previously discussed)

First, Place the tray in the loading position*. Then, place the motor in the correct position at the rear of the tray. Place a gear in position if required*. Next, install a spiral coupler. Finally, connect the motor harness.

GCS-2 Operation and Service Manual

Product Spacer (Option)

Installing - Insert the mounting pins of the product spacer into the column divider

Adjusting - With tray loaded, rotate the product spacer to keep the product upright.

Removing - Pull the mounting pins of the product spacer from the column divider.

Loading A Tray With Products

(In General)

Place tray in the loading position. Begin loading products at the front of the tray and work towards the back. Position the product so the package rest on the tray. Be careful not to force a product into a spiral. If the fit is too light or too loose, change the spiral size. Be sure there are no empty positions between products in each spirals.

(Special Considerations)

- Bagged Products - position package upright, then push tops slightly towards rear of tray
- Thin Packages - position packages upright
- KitKat - the two right most columns of a candy tray are designed to accept the KitKat candy bar.
- Chilled Candy - use the lowest trays for candy that is to be chilled

WARNING

This merchandiser does not have a health control circuit. It is not approved for the vending of perishable food items.

GCS-2 Operation and Service Manual

Installing A Tray In The Merchandiser

Insert the tray so that the tray rollers pass over the tray-guide rollers. Bring the tray roller to rest on the tray guide. Tilt the tray upward. While holding the tray up, push it towards the rear. Stop when the tab on the tray aligns with the opening in the tray guide. Lower the tray until it rests on the tray guide roller. Push the tray in all the way. The tray retaining clip will fall into the locking position.

Relocating A Tray

Remove the tray from the merchandiser. Remove the screw that secures the left tray-guide to the front guide-mounting channel. Refer to the figure below.

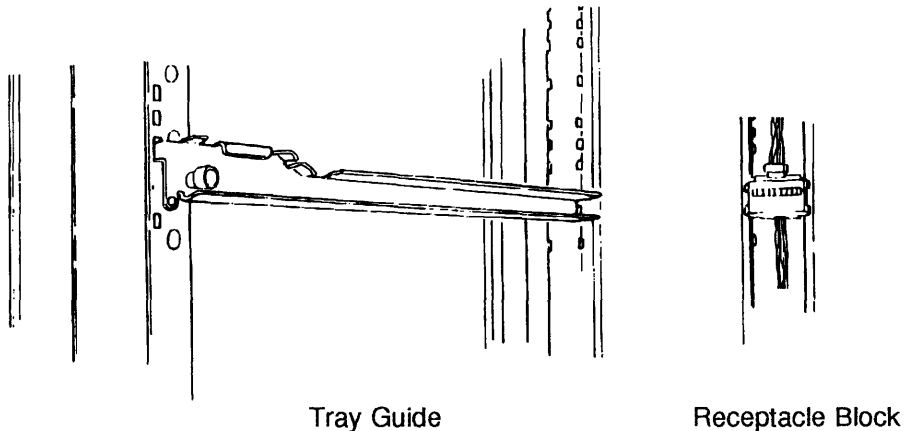

Tap up on the tray guide and unseat the guide rail tabs from the channel slots. Pull the guide rail away from the channels. Move the tray guide to the desired position.

Insert the guide rail tabs into the channel slots. Tap down on the guide rail to seat the tabs in the channel slots. Replace the screw that secures the guide rail to the front guide mounting channel. Repeat this procedure for the right guide rail.

Disconnect the harness from the receptacle block. Press the blade of a slotted-head screw driver between one of the receptacle block locking tabs and the receptacle mounting channel. This will unseat the locking tab. Pull the receptacle block away from the channel and move to the desired position. Push the tabs of the receptacle block into the slots in the channel. Reconnect the harness to the receptacle block and return the tray to the merchandiser.

GCS-2 Operation and Service Manual

Preparing the merchandiser for vending "Lunch Bucket"

Because the weight and shape of the package, Glasco recommends that this product be vended only from the bottom tray. To vend this product, two adjacent positions must be coupled together. The left spiral coupler should be installed one position counter-clockwise from the vertical position. The right spiral coupler should be installed one position clockwise from the vertical position.

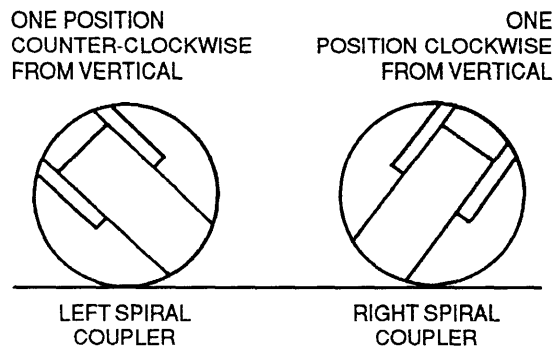

AS VIEWED FROM THE FRONT OF THE TRAY

Replace the current spirals with six-count spirals. A pad can be installed in the bottom of the delivery pan to quiet and cushion the delivery. The figure below shows the correct loading of the "Lunch Bucket."

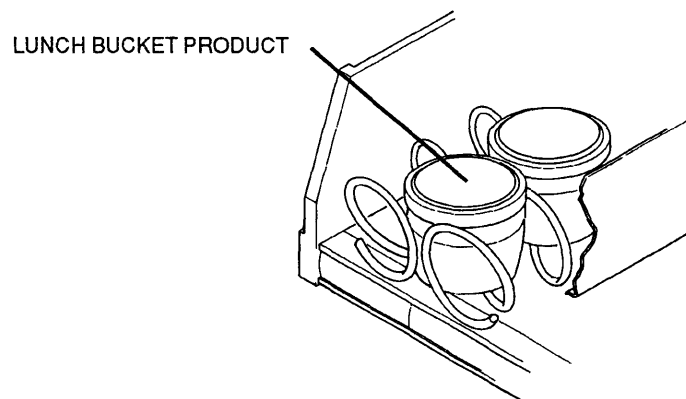

Positioning The Tray For Vending

Lift the tray until it is parallel to the floor. Push the tray towards the back of the cabinet. Mate the connector on the back of the tray with the receptacle block. Lock the retaining clips on the sides of the tray into position.

GCS-2 Operation and Service Manual

Price Labels

Price labels are printed on coiled-up rolls. You will find these in the plastic bag that contained this manual. There are two types of price rolls: Dollar rolls (1 to 12 in increments of 1) and Cents rolls (00 to 95 in increments of 05)

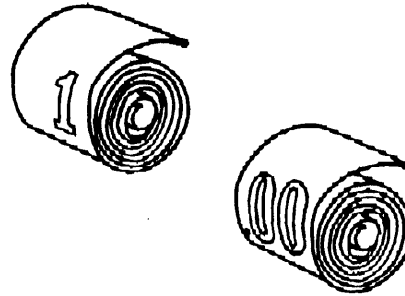

Installation

There are three pairs of slots in the front of the tray. Insert the dollar roll in the left-most pair of slots if the price is \$1.00 or more. Insert the cents roll in the center pair of slots. The low-number end of the roll goes in the top slot and the high-number end of the roll goes in the bottom slot.

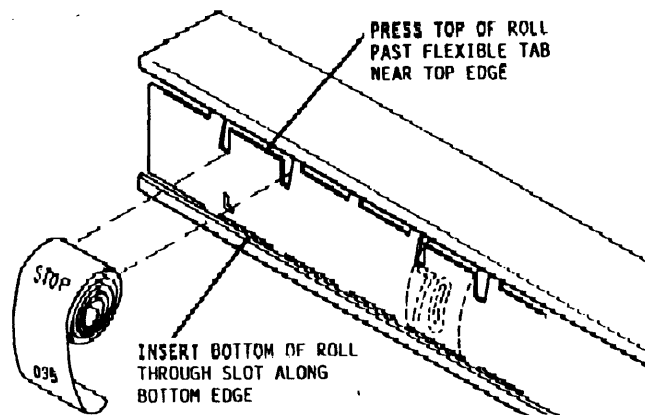

Adjustment

You can set selection prices within the following range:

Minimum Price	\$.00
Maximum Price	\$12.95
Increment	\$.05

Use your thumb to move each price roll up or down as needed to set the desired price.

GCS-2 Operation and Service Manual

Selection ID labels

Selection ID numbers are printed on clear plastic labels. You will find these in the plastic bag that contained this manual.

Installation

The price label should be installed first. Press the two long edges of the label together. Snap the label into position on the front of the tray. The following table illustrates which label goes with which selection.

MOTOR POSITION (For a 6-Tray Merchandiser)

TOP TRAY	TRAY A	A0	A1	A2	A3	A4	A5	A6	A7	A8	A9
	TRAY B	B0	B1	B2	B3	B4	B5	B6	B7	B8	B9
	TRAY C	C0	C1	C2	C3	C4	C5	C6	C7	C8	C9
	TRAY D	D0	D1	D2	D3	D4	D5	D6	D7	D8	D9
BOTTOM TRAY	TRAY E	E0	E1	E2	E3	E4	E5	E6	E7	E8	E9
	TRAY F	F0	F1	F2	F3	F4	F5	F6	F7	F8	F9

EXAMPLE OF A
BASIC SNACK
TRAY

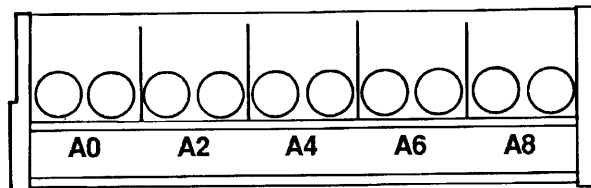

EXAMPLE OF A
BASIC CANDY
TRAY

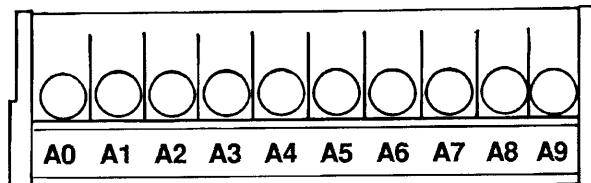

GCS-2 Operation and Service Manual

PROGRAMMING

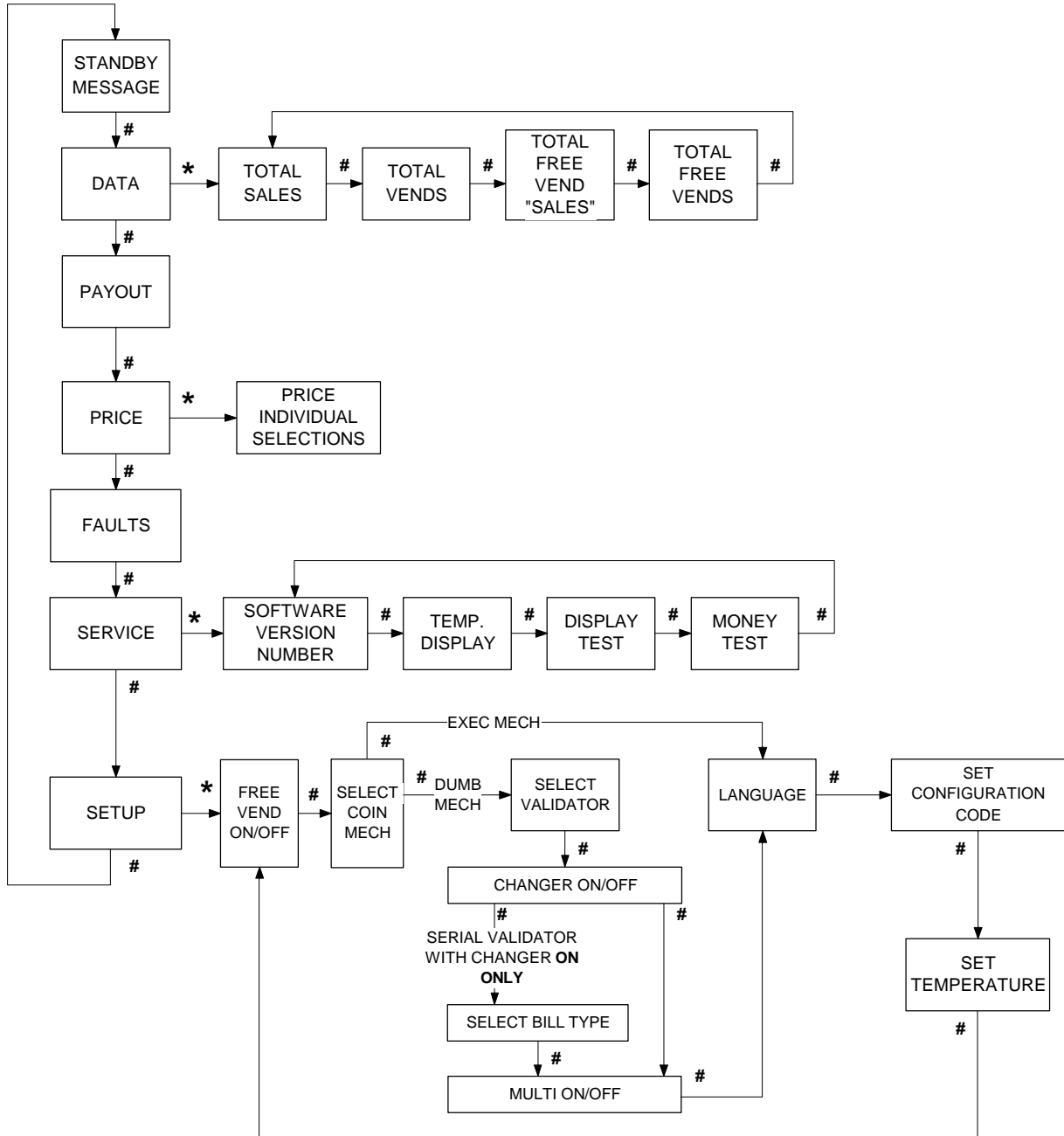

The diagram on this page is a map of the programming functions in your merchandiser. These functions are described in greater detail, but this map will help you get around once you are familiar with how programming works. The symbols * and # represent special keys that move you around inside the programming modes, and from one mode to another. As you can see on the diagram, these symbols show up in the pathways in and around the modes. Not shown, but equally important is the H key. Pressing H at any point will return you to the main screen in a mode. For example, press H at the **LANGUAGE** screen, and you will return to **SETUP**. Pressing H a second time returns you to the standby message.

GCS-2 Operation and Service Manual

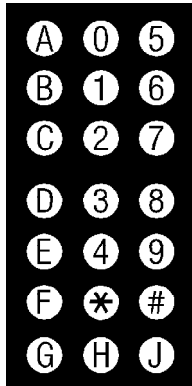

THE KEYPAD

During vending, customers use the keypad to make selections. When you pull the door switch to the ON position, the keypad becomes your programming input device. For reference, we will show the keypad on all the pages.

DATA

View four types of data:

- TOT\$ = Total Machine Sales
- TOT = Total Machine Vends
- FRV\$ = Total Free Vend "Sales"
- FRV = Total Free Vends

This data is nonresettable.

NOTE

At any time you can press **H** once to return to the DATA display. Press **H** again to return to the standby message.

1. Pull out the door switch button to the ON position.
2. Press **#** until the display shows DATA.
3. Press *****. The display shows TOT\$.XX. This is the dollar and cents amount of machine sales.
4. Press **#**. The display shows TOT XX. This is the total count of all vends including free vends.
5. Press **#**. The display shows FRV\$.XX. This is the dollar and cents amount of free vend "sales".
6. Press **#**. The display shows FRV .XX. This is the total count of free vends.
7. Press **#** to return to step 3, or **H** to exit.

GCS-2 Operation and Service Manual

PAYOUT

Payout coins:

1. Pull out the door switch button to the ON position.
2. Press # until the display shows N . D . Q . = 0 . 1 . 2 . This is telling you that pressing 0 pays out Nickels, pressing 1 pays out Dimes, and pressing 2 pays out Quarters.
3. Press the appropriate key once to pay out one coin.
4. Press and hold the appropriate key to pay out coins continuously.
5. Press H to return to the standby message.

PRICE

Set prices for all the selections in your merchandiser:

NOTE

At any time you can press H once to return to the PRICE display. Press H again to return to the standby message.

1. Pull out the door switch button to the ON position.
2. Press # until the display shows PRICE.
3. Press *, and the display shows A0 PR . XX. "XX" is the price for the A0 selection.
4. Press # to step to the next selection.

OR

With the exception of the gum and mint selections (H selections), press the letter/number of the selection you want to price, and it will be displayed immediately. (Since H is the exit key, you can't get directly to the H selections.) To get to the gum and mint selections, press G9, then press #. The "H" selections will be displayed.

5. Enter a new price with the number keys.
6. Price another selection or press H to exit.

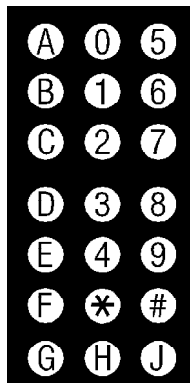

GCS-2 Operation and Service Manual

FAULTS

Display all the active faults on your merchandiser:

NOTE

At any time you can press **H** once to return to the **FAULTS** display. Press **H** again to return to the standby message.

1. Pull out the door switch button to the ON position. If there is a fault on your machine, the display will immediately show the list of errors, one after another. Afterwards, the display shows **FAULTS**. Press ***** to see the fault list again.
2. Press ***** to see the list of faults (in a no-fault condition, the **FAULTS** display remains):

TC ERROR	An error with the tray column
SERIAL VAL	An error in the bill validator (serial only)

When the first item repeats, you have seen all the faults.

2. Press **H** to exit.

SERVICE

View machine status and test certain functions:

NOTE

At any time you can press **H** once to return to the **SERVICE** display. Press **H** again to return to the standby message.

1. Pull out the door switch button to the ON position.
2. Press **#** until the display shows **SERVICE**.
3. Press *****. The display shows the software version number.
4. Press **#**. The internal temperature is displayed.
5. Press **#**. The display shows **DSPL TEST**. Press **J** to briefly light up all segments in the display.
6. Press **#**. The display shows **MONEY 00**. Insert coins and bills into the merchandiser. The amount you inserted is displayed.
7. Press **#** to return to step 3, or **H** to exit.

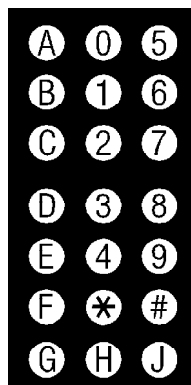

GCS-2 Operation and Service Manual

SETUP

Configure various machine functions:

NOTE

At any time you can press **H** once to return to the **SETUP** display. Press **H** again to return to the standby message.

1. Pull out the door switch button to the **ON** position.
2. Press **#** until the display shows **SETUP**.
3. Press *****. The display shows either **FREE ON** or **FREE OFF**. When **FREE ON** is displayed, all selections are free. Press **J** to switch between **ON** and **OFF**.
4. Press **#**. The display shows either **DUMB MECH** or **EXEC MECH**. Press **J** to switch between **DUMB** and **EXEC** coin mechanisms. If you chose **EXEC**, skip to step 9.
5. Press **#**. The display shows either **SERIAL VAL** or **PULSE \$1**. Press **J** to switch between **SERIAL** and **PULSE** bill validators.
6. Press **#**. The display shows either **CHANGE ON** or **CHANGE OFF**. When **CHANGE ON** is displayed, a customer may receive change for a bill without making a vend. Press **J** to switch between **ON** and **OFF**. Skip to step 8 if you did not select a **SERIAL** bill validator and **CHANGE ON**.
7. Press **#**. The display shows **--- PAY**. This allows you to permit a customer to receive change for a \$1, \$2, and/or \$5 bill. Press **1**, **2**, and/or **5** to display the bills a customer can change.
8. Press **#**. The display shows either **MULTI ON** or **MULTI OFF**. When **MULTI ON** is displayed, a customer may purchase more than one item with a declining balance. Press **J** to switch between **ON** and **OFF**.
9. Press **#**. The display shows either **ENGLISH**, **FRENCH**, or **SPANISH**. Press **J** until your language is displayed.
10. Press **#**. The display shows **CNFIG 2**. This screen lets you tell the software what kind of machine you have. **If your screen does not show CNFIG 2, press the "2" key. YOUR MACHINE MUST BE CONFIGURED LIKE THIS!**
11. Press **#**. The display shows **C - - - - - W**. "C" is Cold, and "W" is Warm. The more dashes between W and C, the warmer the refrigeration module temperature. To make the temperature warmer, keep pressing *****. The dashes fill in the display from left to right. When the display is full of dashes, the next time you press *****, they all disappear, which represents the coldest possible temperature.
12. Press **#** to return to step 3, or **H** to return to the standby message.

